



ELECTRIC MULTI-LIFT

λ INSTRUCTIONS λ PARTS DRAWING λ PARTS LIST

ITEM # 10738

- LAWN MOWER - SNOW BLOWER - GARDEN TILLER - POWER WASHER
- GENERATORS - MULTIPLE USES

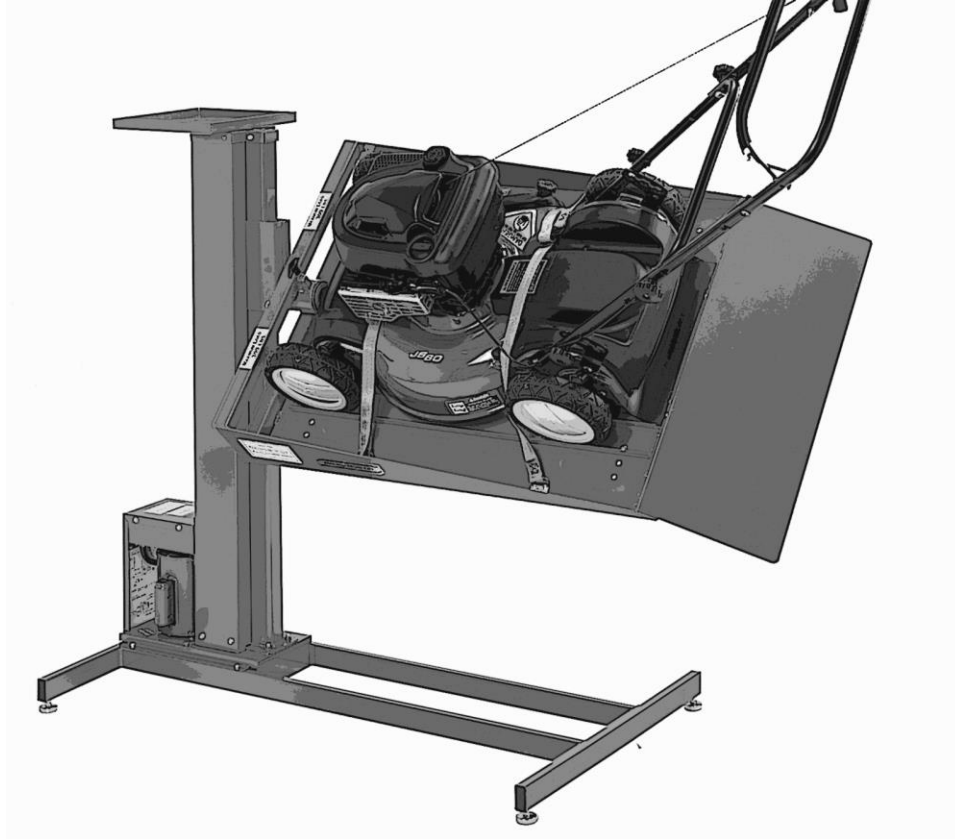

WARNING: READ INSTRUCTIONS BEFORE OPERATING

FOR YOUR SAFETY

- λ This is for operation on 115 volt, 60 Hz. circuit only.
- λ Do not remove ground prong from plug.
- λ Center load on table - 300 lbs. maximum
- λ Keep hands and tools from under carriage.
- λ Do not mount table when in elevated position

⚠ DO NOT REMOVE THE PIECES OF CARDBOARD ON THE DRIVE ASSEMBLY MAST UNTIL INSTRUCTED TO DO SO. REMOVAL COULD CAUSE DAMAGE TO THE LIMIT SWITCHES.

ASSEMBLY INSTRUCTIONS

NOTE: ASSEMBLY OF THE MULTI-LIFT REQUIRES TWO PEOPLE.

BOX UNPACKING

1. Remove the base and set on the floor at the location you wish to assemble the lift. There are four adjustable swivel guides to accommodate minor floor leveling.
2. Remove drive assembly from the carton and place on Styrofoam packing.
3. Remove the lift table and set on the floor out of the way for now, or leave in box.

DRIVE ASSEMBLY INSTALLATION

1. Being careful not to damage the motor pulley, set drive assemble on the base and secure with four 10-32" x 1/2" screws. Torque to 20 in-lbs.
2. Utilizing the carton as a support for the top of the drive assembly, lay the complete lift on one side.
3. Finish securing the drive assembly to the base by installing four 3/8" x 1" bolts and lock washers. Use a 9/16" socket and torque to 25 ft. lbs.
4. Install the 6" drive pulley and V-belt. The pulley should be place on the drive shaft with allen screw side facing down. With allen screw facing flat part of the drive shaft tighten with a 5/32" allen wrench. Torque to 13 ft-lbs.

BELT ADJUSTMENT

Belt may be adjusted by loosening the four nuts on bottom of the motor mount. Be careful not to over tighten the V-belt as this can put stress on the thrust bearing. Be sure to have 1/2" of deflection on the belt.

LIFT TABLE INSTALLATION

1. Put lift back in upright position. You are now ready to install the lift table. DO NOT remove the cardboard on drive assemble.
2. Utilizing 2 people pick up the lift table and slide onto roller box pivot tube. Make certain that the T-Knob is locked in the level position.
3. Spread the spiral retainer ring and start one end in groove of roller box pivot tube and slide remainder of ring into place.
4. Grease pivot tube (zerk located on side of pivot tube) using No.2 EP grade gear grease.

TOOL TRAY INSTALLATION

Remove two screw from top of unit. Align tool tray holes with holes on unit. Reinstall two screws. Torque to 20 in-lbs.

IMPORTANT: You may now plug the unit into a 115 Volt, 60 Hz. grounded outlet. After lowering table and removing the cardboard at the top of drive assembly mast you are ready to put the Multi-Lift to work.

➔ **NOTE: This unit is always shipped in the up position. You must go down to the HOME position before raising it.**

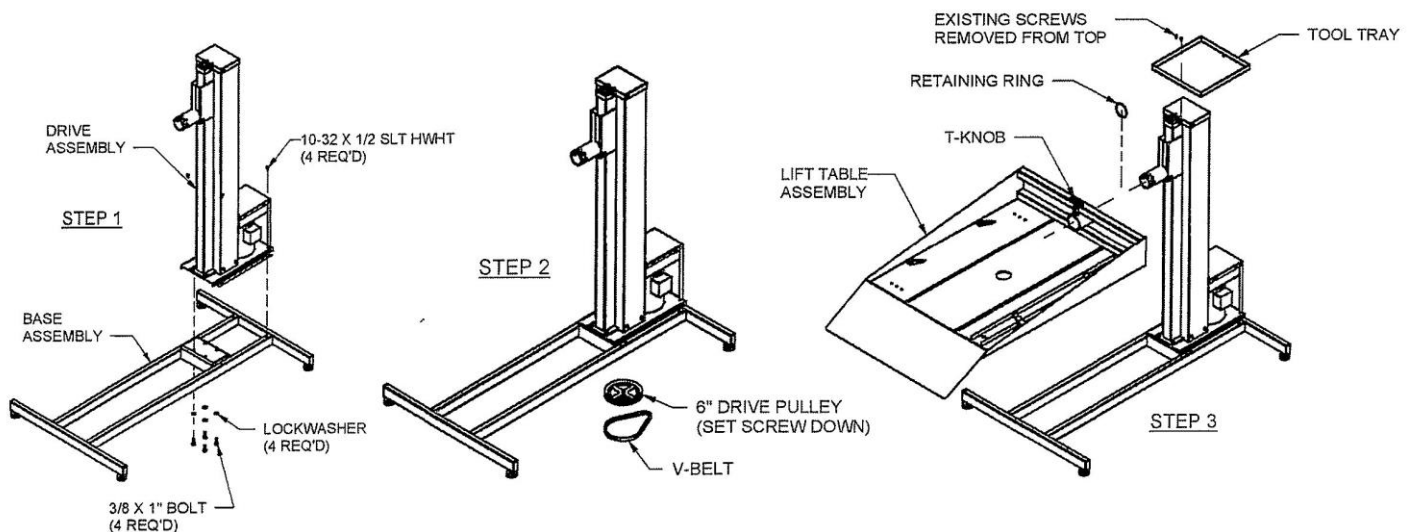

▲ Denotes special Safety Cautions Warning. Read entire manual to comply with all Safety & Service Precautions.

POWER SUPPLY

▲ WARNING: THIS LIFT IS EQUIPPED WITH A 3-PRONG PLUG WHICH MUST BE PLUGGED INTO A GROUNDED 115 VOLT, 60 HZ. POWER SUPPLY FOR YOUR SAFETY. REMOVING GROUND PLUG PRONG FROM PLUG OR FAILURE TO PLUG INTO A GROUNDED RECEPTACLE MAY RESULT IN FATAL ELECTRICAL SHOCK.

AUXILIARY CENTER TABLE PLATE

The Electric Multi-Lift Table comes with the center pan installed. The center pan can be taken off by removing the bolts. Store in a convenient location for later use.

LOADING AND LIFTING PUSH STYLE LAWNMOWERS

▲ WARNING: NEVER OPERATE (START ENGINE) ON ANY EQUIPMENT WHILE IT IS LOADED ON THE MULTI-LIFT.

1. Make certain the wheel guide channel is firmly bolted to the same side of the lift table as the tracking wheels of the lawnmower. (Note: Some lawnmowers have offset wheels on one side to compensate for grass discharge chute). The wheel channels are secured with two 1/4" bolts.
2. Utilizing the fixed ramp, load the lawnmower onto the Multi-Lift table.
3. Utilizing the two tie-down straps provided with the Multi-Lift, secure the mower to the table top. Do not leave any slack.

▲ WARNING: FAILURE TO FULLY SECURE THE ITEM YOU ARE LIFTING COULD RESULT IN INJURY. PARTICULARLY IF YOU INTEND TO ROTATE THE LIFT TABLE.

4. After securing lawnmower move to the front (motor side) of the lift. Making certain that all pinch points are free from hands and legs and that all body parts are clear from protruding obstacle (i.e. handles, mufflers etc.)

LIFT TABLE ROTATION

▲ WARNING: ROTATING AN ITEM WITH LIQUIDS (GAS, OIL ETC.) CAN CAUSE SPILLAGE. MAKE CERTAIN HAZARDOUS MATERIALS ARE DRAINED BEFORE ATTEMPTING TO ROTATE. ALSO DOUBLE CHECK TIE-DOWN STRAPS. ALWAYS BE AWARE OF PROTRUDING PARTS (HANDLES, MUFFLERS ETC). MAKE CERTAIN THE AREA IS CLEAR OF ANYONE WHO COULD GET INJURED DURING ROTATION OR ANY OTHER TIME WHILE THE EQUIPMENT IS LOADED.

1. With one hand, firmly grip the front end of the lift table (square tubing). You may rotate the table either way.
2. With the other hand, pull the T-Head release pin at the swivel head.
3. Rotate the table to the desired location. There are two points each direction. One at 45 degrees and the other at 90 degrees. Make certain the T-Head pin is secured in a hole on the swivel head before releasing the lift table.
4. To return the lift table to the level position, reverse above instructions.

TO LOWER LIFT

1. Make certain the area is clear of anyone who could get injured.
2. Hold in the down push button switch until lift is at the desired height or until it reaches ground level.
3. There is a limit switch which will automatically stop the downward motion of the lift table when ground level is reached, when the lift is at a level position. However, caution must be taken when the platform is rotated to a 45 or 90 degree angle, the switch does not activate when the platform reaches the floor.

▲ LOADING OTHER EQUIPMENT

The Handy Multi-Lift is most specifically designed for use with push style lawnmowers. It, however can be utilized for a multitude of different items that need to be lifted. Always make certain that whatever items is being lifted can be safely loaded, secured and unloaded before attempting to lift with this equipment.

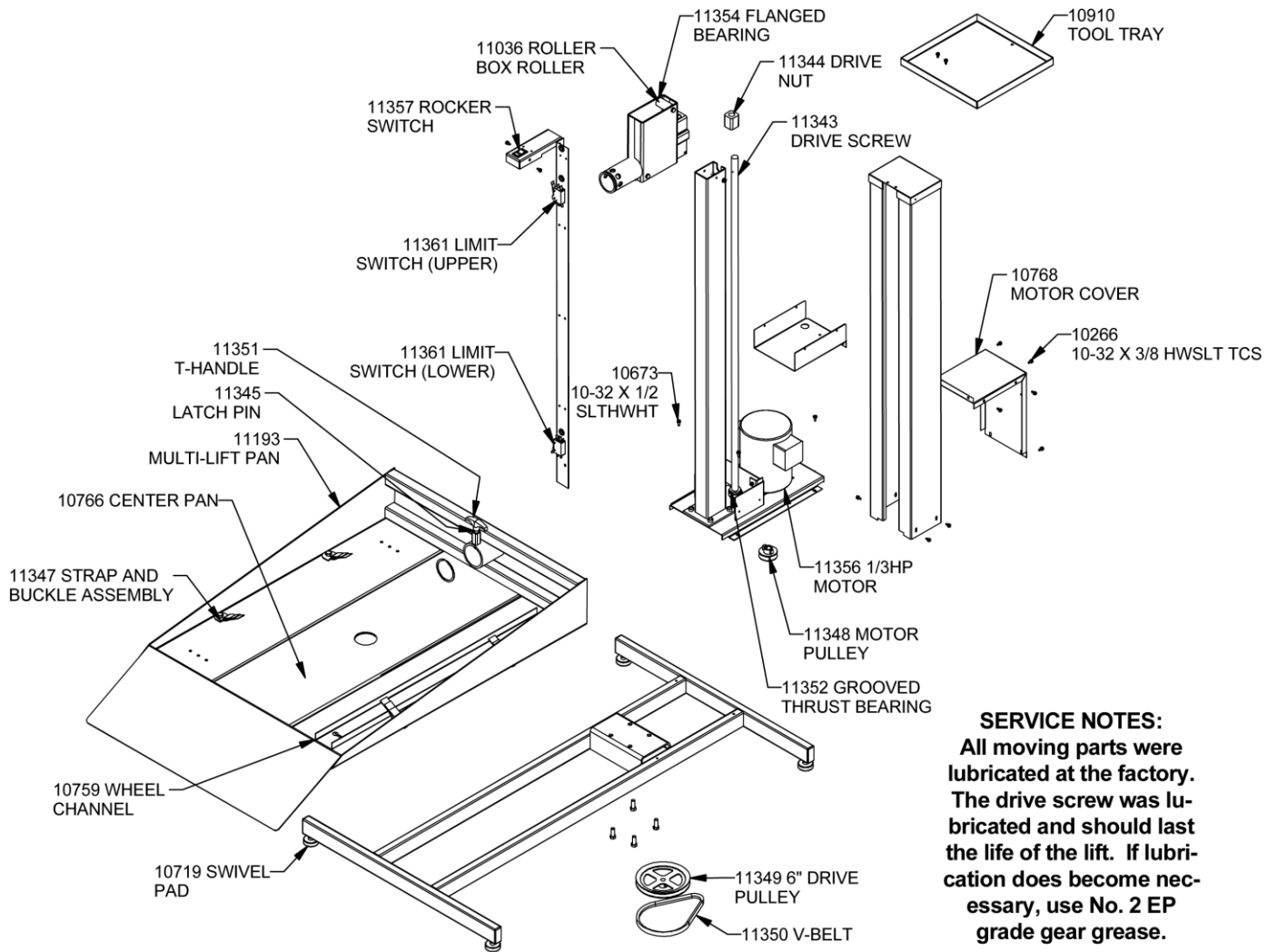

SERVICE NOTES:
All moving parts were lubricated at the factory. The drive screw was lubricated and should last the life of the lift. If lubrication does become necessary, use No. 2 EP grade gear grease.

QTY	PART No.	DESCRIPTION	QTY	PART No.	DESCRIPTION
4	10719	SWIVEL PAD	1	11348	2" - MOTOR PULLEY
1	10759	WHEEL CHANNEL	1	11349	6" - DRIVE PULLEY
1	10766	CENTER PAN	1	11350	V-BELT
1	10768	MOTOR COVER	1	11351	T-HANDLE
1	10910	TOOL TRAY	1	11352	GROOVED THRUST BEARING
2	11036	ROLLER BOX ROLLER	4	11354	FLANGED BEARING
1	11343	DRIVE SCREW	1	11356	1/3 HP MOTOR
1	11345	LATCH PIN	1	11357	ROCKER SWITCH
2	11347	STRAP & BUCKLE ASSY	2	11361	LIMIT SWITCH

FOR REPLACEMENT PARTS AND SERVICE SUPPORT CALL: 855-752-5446

HANDY LIMITED WARRANTY

Handy, Division of Janco Industries, Inc. warrants to the original purchaser of this product, all parts to be free from defects in manufacture for a period of one (1) year from date of delivery. Notice of a defective part must be received in writing at Handy Division of Janco Industries, Inc. within one (1) year of purchase. All defective parts must be returned to Handy Industries and which, upon our examination any parts which are defective in manufacture or workmanship, will be replaced or put in good operating condition. This warranty does not apply to damage resulting from accident, improper installation, repair, operation or maintenance, negligence or neglect. THE COST OF SUCH REPLACEMENT OR REPAIR SHALL BE EXCLUSIVE REMEDY FOR ANY BREACH OF ANY WARRANTY AND HANDY INDUSTRIES SHALL NOT BE LIABLE TO ANY PERSON FOR CONSEQUENTIAL DAMAGE, OR INJURY, OR COMMERCIAL LOSS RESULTING FROM ANY BREACH OF WARRANTY. HANDY INDUSTRIES MAKES NO WARRANTY OR MERCHANTABILITY, MAKES NO WARRANTY OF FITNESS FOR A PARTICULAR PURPOSE AND MAKES NO OTHER WARRANTY EXPRESSED OR IMPLIED, INCLUDING IMPLIED WARRANTY ARISING FROM THE COURSE OR DEALING OR USAGE OF THE TRADE.

HANDY DIVISION OF JANCO INDUSTRIES, INC. PH: 855-752-5446 FAX 641-594-3330 www.handyindustries.com